

SANITARY PRESSURE REDUCING VALVE P130K

DESCRIPTION

The ADCAPure P130K is a series of direct acting, diaphragm sensing pressure reducing valves.

These regulators, available with spring or dome-loading, are designed for use with clean air, nitrogen, carbon dioxide, oxygen, argon and other gases or liquids compatible with the construction materials and valve design.

Specifically designed for the high purity gas systems found in the pharmaceutical, cosmetic, fine chemical and food & beverage processes.

MAIN FEATURES

Compact design.

Non-rising adjustment knob.

FDA / USP Class VI compliant seals.

Completely machined from 316L stainless steel bar stock, no castings or forgings are used.

STANDARD SURFACE FINISH

Internal wetted parts: $\leq 0,51$ micron Ra – SF1.

External: $\leq 0,76$ micron Ra – SF3.

Other surface conditions see IS PV20.00 E – Technical information.

Ultrasonic cleaning.

OPTIONS:

Self relieving.

Leakage line connection (1/8").

Gauge connection on body.

Different soft sealings for liquids and gases.

Top cap (adjustment screw with cover).

Dome-loaded version.

USE:

Clean air, nitrogen, carbon dioxide, oxygen, argon and other gases or liquids compatible with the construction.

AVAILABLE

MODELS:

P130K.

SIZES:

1/2" to 3/4"; DN 08 to DN 20.

REGULATING

RANGES:

0,2 to 1,5 bar; 0,3 to 3 bar; 2 to 8 bar.

CONNECTIONS:

ASME BPE, DIN and ISO clamp ferrules or tube weld (ETO) ends. Others on request.

PACKAGING:

Assembling and packaging in a clean room certified according to ISO 14644-1.

The product is end capped and sealed with recyclable thermo-shrinkable plastic film, to avoid contamination.

INSTALLATION:

Horizontal installation is recommended. See IMI – Installation and maintenance instructions.

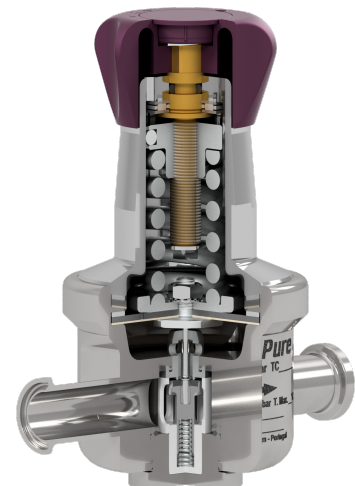

LIMITING CONDITIONS

Valve model	P130K
Body design conditions	PN 16
Maximum upstream pressure	16 bar
Maximum downstream pressure	8 bar
Minimum downstream pressure	0,2 bar
Maximum design temperature *	150 °C

* Others on request.

CE MARKING – GROUP 2 (PED – European Directive)

PN 16	Category
1/2" to 3/4" – DN 08 to 20	SEP

FLOW RATE COEFFICIENTS (m ³ /h)						
SIZE	ASME BPE		DIN		ISO	
	1/2" to 3/4"		DN 10 to DN 20		DN 08 to DN 15	
Kvs	0,7	1,3	0,7	1,3	0,7	1,3

DIMENSIONS (mm) ASME BPE											
SIZE	A	B	C	D	d1	d2	d3	E	F	H	WEIGHT (kg) *
1/2"	130	28	125	80	25	15,75	1/4"	66,5	25	9,4	2,4
3/4"	130	28	125	80	25	15,75	1/4"	66,5	25	15,75	2,4

* Valves with nylon adjustment knob weigh 0,3 kg less.

DIMENSIONS (mm) DIN											
SIZE	A	B	C	D	d1	d2	d3	E	F	H	WEIGHT (kg) *
DN 10	120	28	125	80	25	15,75	1/4"	66,5	34	10	2,5
DN 15	120	28	125	80	25	15,75	1/4"	66,5	34	16	2,4
DN 20	120	28	125	80	25	15,75	1/4"	66,5	34	20	2,6

* Valves with nylon adjustment knob weigh 0,3 kg less.

Remarks: Clamp ferrules according to DIN 32676-A; Tube weld (ETO) according to DIN 11866-A (DIN 11850-2).

DIMENSIONS (mm) ISO											
SIZE	A	B	C	D	d1	d2	d3	E	F	H	WEIGHT (kg) *
DN 08	120	28	125	80	25	15,75	1/4"	66,5	25	10,3	2,5
DN 10	120	28	125	80	25	15,75	1/4"	66,5	25	14	2,5
DN 15	120	28	125	80	25	15,75	1/4"	66,5	50,5	18,1	2,3

* Valves with nylon adjustment knob weigh 0,3 kg less.

Remarks: Clamp ferrules according to DIN 32676-B; Tube weld (ETO) according to DIN 11866-B (ISO 1127).

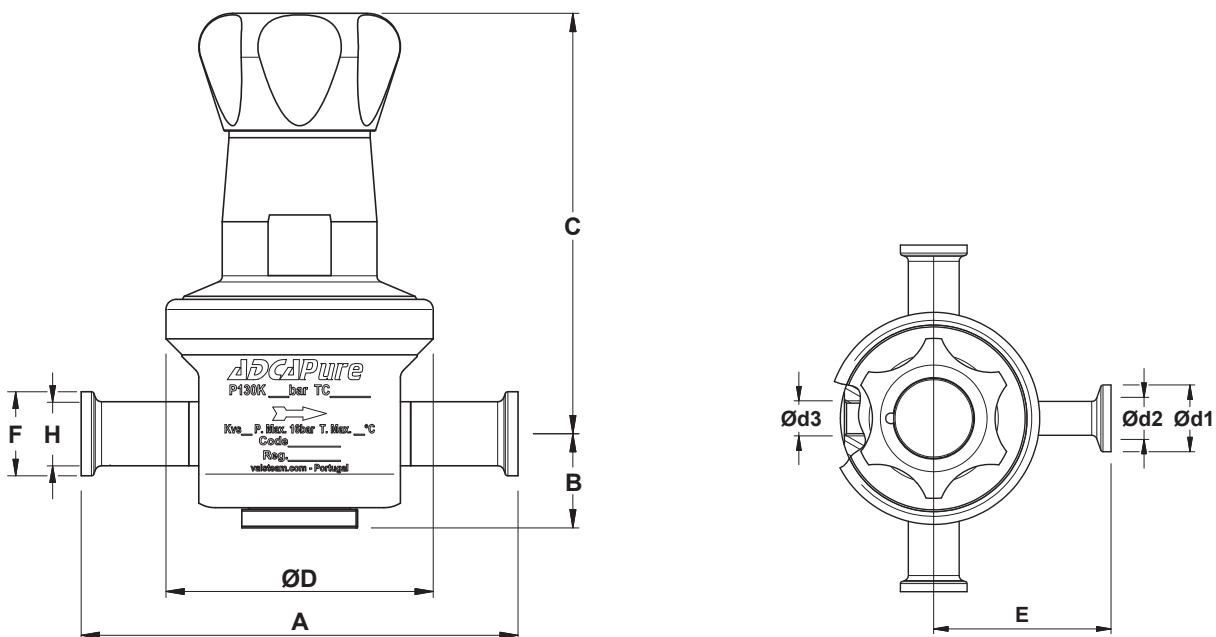

Optional pressure gauge connection

MATERIALS

POS. N°	DESIGNATION	MATERIAL
1	Valve body	AISI 316L / 1.4404
2	Cover	AISI 316L / 1.4404
3	Bottom cover	AISI 316L / 1.4404
4	* O-ring	EPDM
5	* Piston	AISI 316L / 1.4404
6	* Valve head	** EPDM; PTFE; FPM
8	* Valve spring	Spring steel
9	* Seat	AISI 316L / 1.4404
10	* O-ring	EPDM
11	* Guide	PEEK
12	* Stem	AISI 316L / 1.4404
13	* O-ring a)	EPDM
14	Pusher disk	AISI 316L / 1.4404
15	* Lower diaphragm	PTFE (Gylon)
16	* Upper diaphragm	EPDM
17	Washer	AISI 304 / 1.4301
18	Plate	AISI 316 / 1.4401
19	Nut	AISI 304 / 1.4301
20	* Serrated washer	AISI 304 / 1.4301
21	* Adjustment spring	AISI 302 / 1.4300
22	Spring guide	AISI 316 / 1.4401
23	Adjustment screw	Brass
24	Washer	Stainless steel A2-70
25	Bolt	Stainless steel A2-70
26	Adjustment knob	AISI 316L / 1.4404 or Nylon
27	O-ring	NBR
28	Bearing	Corrosion resistant steel
29	Shaft ring	Stainless steel
30	Cover nut	Plastic
31	Leakage line ring	AISI 316 / 1.4401
32	* O-ring	EPDM
33	O-ring	NBR
34	Bolt	AISI 304 / 1.4301
35	O-ring	Viton
36	Compression fitting	AISI 304 / 1.4301

* Available spare parts. ** Others on request.

a) Only for versions with self-relieving option.

Remarks: FDA / USP Class VI seals certificate on request.

All valves have a serial number. In case of non-standard valves, this number must be supplied if spare parts are ordered.

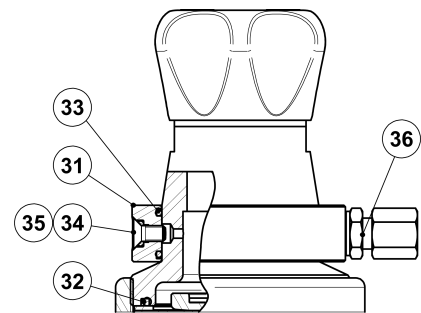
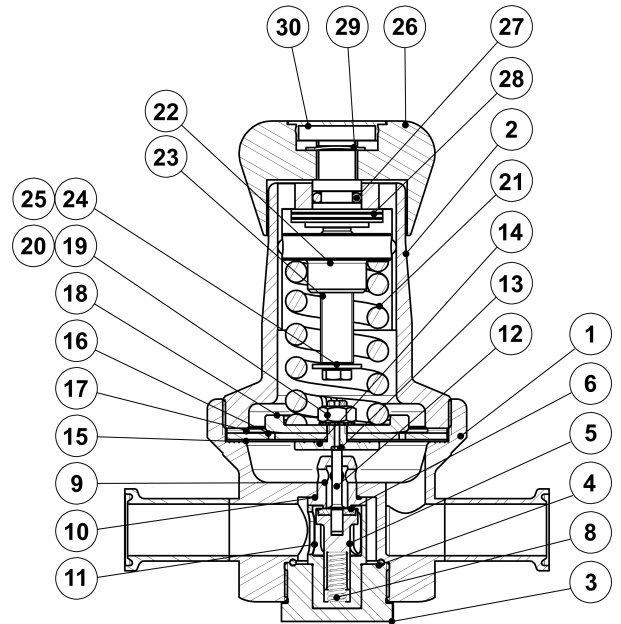

Optional leakage line connection (1/8")

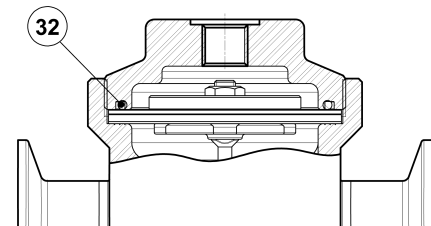

Dome-loaded top

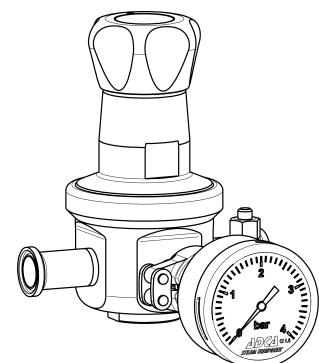

Optional pressure gauge connection

ORDERING CODES P130K												
Valve model	P3K	1	2	T	M	X	I	X	X	X	DI	08
P130K – AISI 316L / 1.4404 diaphragm sensing pressure reducing valve	P3K											
Regulating range												
0,2 to 1,5 bar		1										
0,3 to 3 bar		2										
2 to 8 bar		3										
0,2 to 8 bar (dome-loaded) a)		A										
Flow rate coefficient												
Kvs 0,7		3										
Kvs 1,3		5										
Diaphragm												
PTFE (Gylon)				T								
EPDM (non-standard)				E								
Seat material												
Metal to metal (non-standard)					M							
EPDM					E							
PTFE					T							
FPM / Viton (FDA approval only)					V							
Relieving and leakage line connection												
Non-relieving b)						X						
Non-relieving with leakage line connection						N						
Relieving (only for non-dangerous gases)						R						
Relieving with leakage line connection						L						
Adjustment knob and top cap												
Stainless steel adjustment knob							I					
Nylon adjustment knob							P					
Top cap (adjustment screw with cover)							T					
Dome-loaded top b)							X					
Gauge port options												
Without gauge ports								X				
Tri-clamp gauge port on the left side (rel. to the flow direction) – downstream pressure								7				
Tri-clamp gauge port on the right side (rel. to the flow direction) – downstream pressure								6				
Tri-clamp gauge port on both sides – downstream pressure								5				
Threaded gauge port on the left side (rel. to the flow direction) – downstream pressure – ISO 7 Rp 1/4"								4				
Threaded gauge port on the right side (rel. to the flow direction) – downstream pressure – ISO 7 Rp 1/4"								3				
Threaded gauge port on both sides – downstream pressure – ISO 7 Rp 1/4"								2				
Threaded gauge port on the left side (rel. to the flow direction) – downstream pressure – 1/4" NPT								W				
Threaded gauge port on the right side (rel. to the flow direction) – downstream pressure – 1/4" NPT								Y				
Threaded gauge port on both sides – downstream pressure – 1/4" NPT								Z				
Surface finish c)												
Standard surface finish									X			
Mirror mechanical polished external surfaces (SF1)									P			
Electropolished internal wetted parts (SF5)									E			
Special features												
None										X		
Degreased for oxygen										O		
Pipe connection												
Clamp ferrule ASME BPE											D	
Clamp ferrule DIN (DIN 32676-A)											F	
Clamp ferrule ISO (DIN 32676-B)											E	
Tube weld (ETO) according to ASME BPE											DI	
Tube weld (ETO) according to DIN 11866-A (DIN 11850-2)											FI	
Tube weld (ETO) according to DIN 11866-B (ISO 1127)											EI	
Size												
DN 08												08
DN 10												10
1/2" or DN 15												15
3/4" or DN 20												20
Special valves / Extras												
Full description or additional codes have to be added in case of non-standard combination												E

a) The loading control pressure can be up to a maximum of 1,2 bar above the required downstream pressure; b) These options must be chosen in case of dome-loaded version; c) Consult IS PV20.00 for further details and other surface finish options.