

HUMIDITY SEPARATORS S25/SS (Stainless steel) PN16 – PN40

DESCRIPTION

S-25SS series centrifugal separators remove moisture from steam and compressed air pipelines. Steam and compressed air passing through the separator and as a result of centrifugal forces, impact and swirling effects, separate the particles with a heavier specific gravity, such as water and oil droplets, moisture in suspension, dirt and scale.

The condensate collected at the bottom of the separator, must be automatically drained by a suitable steam or compressed air trap.

Connections are flanged.

MAIN FEATURES

Several possibilities of installation.

No moving parts.



OPTIONS: Condensate flanged connection.

USE: Steam, compressed air and other gases (Group 2).

AVAILABLE MODELS: S25/SS - Stainless steel body.

SIZES: DN15 to DN300.

PIPE CONNECTIONS: Flanged EN1092-1 PN16 and PN40
ANSI Class 150 lbs and Class 300 lbs
Female screwed BSP or NPT on request.

INSTALLATION: Always with the condensate discharge pointing downwards.
See IMI, installation and maintenance instructions.

HOW TO SELECT: Generally, in an existing plant it is advisable to fit a separator of the same size of the pipe line. Pressure drop is normally negligible. For approximate pressure drop calculation please consult.

CE MARKING - PED (European Directive)					
RATING	SIZE	CAT.	RATING	SIZE	CAT.
PN16	DN15 to DN25	SEP	PN40	DN15 to DN32	1
	DN32 to DN50	1		DN40 to DN80	2
	DN65 to DN125	2		DN100 to DN150	3
	DN150 to DN200	3		DN200 to DN300	4
	DN250 to DN300	4		-	-

LIMITING CONDITIONS **								
Rating	Press. bar	Temp. °C	Rating	Press. bar	Temp. °C	Rating	Press. bar	Temp. °C
PN16	16	50	ANSI Cl.150 lbs	16	50	PN40 ANSI CL.300lbs	40	50
	16	100		16	100		40	100
	13 *	195		13 *	195		32 *	239
	12	250		-	-		30	300

*PMO-Max.operating pressure for saturated steam.

Minimum operating temp.: -10°C. Design code: AD-Merkblatt

** Rating according to EN1092:2007.

APPROXIMATE DIMENSIONS (mm)														
FLANGED EN1092-1 - ANSI														
SIZE DN	A PN16	A 150 lbs	B	C	D	E	J	L PN16	L 150 lbs	F	G PN16	G 150 lbs	VOL. dm3	WGT. Kg
15	230	250	114	260	185	75	115	144	135	1/2"	245	255	2	5,4
20	230	255	114	260	185	75	115	136	123	1/2"	245	255	2,5	5,8
25	230	262	114	300	200	100	135	142	126	1/2"	260	270	3	6,8
32	260	290	140	395	285	110	155	194	200	1/2"	345	355	5	11,4
40	260	294	140	435	325	110	165	243	226	1/2"	385	395	5,7	12,6
50	310	341	168	505	385	120	190	281	265	1/2"	445	455	10,5	18,4
65	380	430	219	550	410	140	240	275	250	3/4"	470	483	18,5	29,8
80	400	440	219	610	462	148	260	306	286	3/4"	522	535	25	33,6
100	470	520	273	715	528	187	330	326	302	3/4"	588	601	35,4	49,7
125	535	605	324	845	630	215	403	380	346	1"	688	704	50	76
150	565	633	356	960	690	270	457	428	394	1"	758	774	75	104
200	605	685	406	1170	880	290	545	485	446	1"	948	965	140	168,5
250	720	784	508	1540	1140	400	671	714	682	1 1/2"	1210	1227	280	318
300	860	933	610	1700	1172	528	800	662	626	1 1/2"	1262	1279	452	463
SIZE DN	A PN40	A 300 lbs	B	C	D	E	J	L PN40	L 300 lbs	F	G PN40	G 300 lbs	VOL. dm3	WGT. Kg
15	230	259	114	275	190	85	115	144	130	1/2"	250	264	2	6,6
20	230	264	114	275	190	85	115	136	119	1/2"	250	264	2,5	7,4
25	230	274	114	300	200	100	135	142	120	1/2"	260	274	3	8,5
32	260	303	140	395	285	110	155	194	215	1/2"	345	360	5	13
40	260	307	140	435	325	110	165	243	220	1/2"	385	399	5,7	16
50	310	354	168	505	375	130	190	281	259	1/2"	435	450	10,5	24
65	394	442	219	550	395	155	240	268	244	3/4"	455	472	18,5	39
80	410	459	219	610	450	160	260	298	277	3/4"	510	527	25	44
100	490	530	273	715	510	205	330	313	293	3/4"	570	587	35,4	75
125	561	622	324	845	605	260	403	367	337	1"	658	680	50	114
150	605	652	356	960	690	270	457	408	385	1"	754	776	75	131
200	650	700	406	1170	830	340	545	459	436	1"	898	920	140	264
250	810	815	508	1540	1140	400	671	679	666	1 1/2"	1235	1259	280	454
300	914	964	610	1700	1172	528	800	625	597	1 1/2"	1262	1286	452	514

F-screwed drain connection as standard. Alternatively can be supplied flanged EN1092-1 or ANSI on the same class of main dimensions.

Consult factory for certified dimensions and weight. Dimensions subject to change without notice.

Note: the top of separator is supplied with a threaded connection with size not exceeding the size of drain one. This connection is always supplied closed with a threaded socket. It can be used for air vent or balancing pipe connection.

MATERIALS

DESIGNATION	MATERIAL
Body	EN10216-5 / ASTM A312TP316L
Heads	EN10028-7 / ASTM A403 WP316L
Inlet / Outlet pipes	EN10216-5 / ASTM A312TP316L
EN flanges	EN10222-5 / ASTM A182 F316/316L
ANSI flanges	ASTM A182 F316/316L
Sockets	AISI 304 (1.4301) / AISI316 (1.4401)
Internals	EN10272 / ASTM A479/A276-316/316L

EN10204 3.1 certificate available if requested with the order.

FLANGE CONNECTIONS

Rating	SIZE	EN STD.	ANSI STD.
PN16	* DN15 to DN50	EN1092-1 PN40	ANSI B16.5 Cl.150 lbs
PN16	DN65 to DN300	EN1092-1 PN16	ANSI B16.5 Cl.150 lbs
PN40	DN15 to DN300	EN1092-1 PN40	ANSI B16.5 Cl.300 lbs

* Flanges EN 1092-1 PN16 and PN40 from DN15 to DN50 has the same number and size of holes.

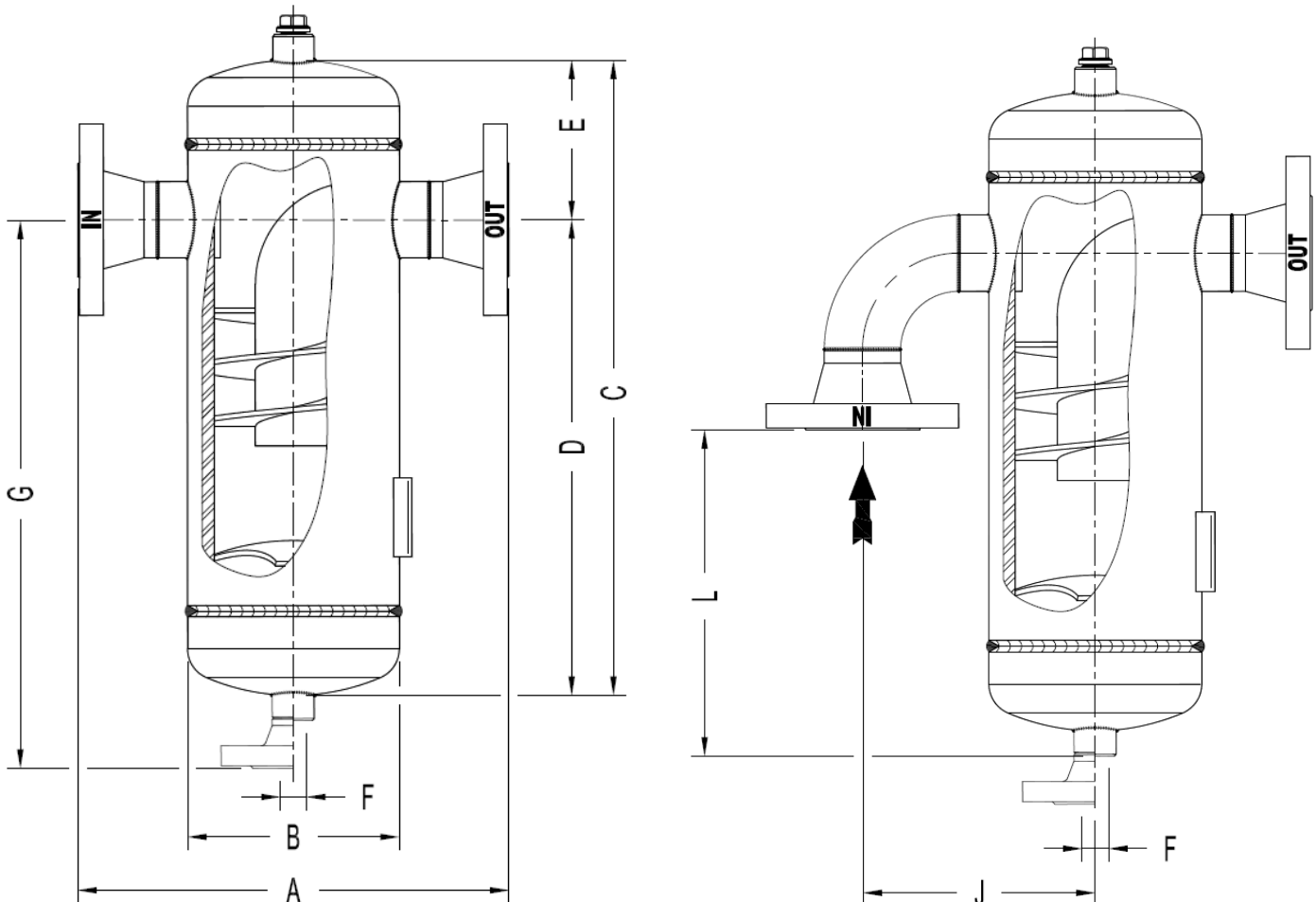

EVH-Elbow vertical inlet / horizontal outlet