

**TEMPERATURE REGULATORS
SELF ACTING - NON BALANCED SIMPLE SEAT
TR40 valves & T series thermostats**

DESCRIPTION

The TR40 valves series were designed for temperature control of heating systems where the valve closes on temperature rising. They are single seated, in order to ensure an excellent tightness, and are intended to be coupled with thermostat models T.205 and T.405. The liquid filling the thermostat expands when the temperature levels of the fluid being heated rise, closing the valve. These valves are used for controlling the temperature in central heating systems, district heating systems and industrial plants.

MAIN FEATURES

Single seated, two way, direct action valve.
Leakages of less than 0,05% of full Kv.

USE: Saturated and superheated steam.
Hot and superheated water.

AVAILABLE MODELS: TR40S – PN40 cast steel valve body.
TR40SS – PN40 stainless steel valve body.

SIZES: DN 15 to DN 25.

CONNECTIONS: Flanged EN 1092-1 PN40.
CONTROL MODE: Proportional.

THERMOSTATS: T.205 - 200N (max. closing force).
T.405 - 400N (max. closing force).

THERMOSTAT RANGES: T.205 – 0-60; 30-90 and 60-120°C.
T.405 – 0-120; 40-160 °C.

CAPILLARY LENGTHS: 3 m as standard.

HOW TO SELECT: Never size the valve according to the pipe diameter in which it has to be fitted but according to the required actual flow of steam or water. Refer to valve calculation data sheet or consult the factory.

COOLING UNITS: Cooling units protect the stuffing box of the thermostat. Type K1 is recommended at valve temperatures between 150 and 250 °C.

INSTALLATION: Horizontal installation with the thermostat in the vertical position in order to reduce wear. In case of valve temperatures up to 150 °C, the thermostat may be fitted below or above the valve. In case of valve temperatures between 150 and 250 °C, a cooling unit type K1 has to be applied with connection downwards. An “Y” strainer should be installed upstream the valve.
See IMI – Installation and maintenance instructions.

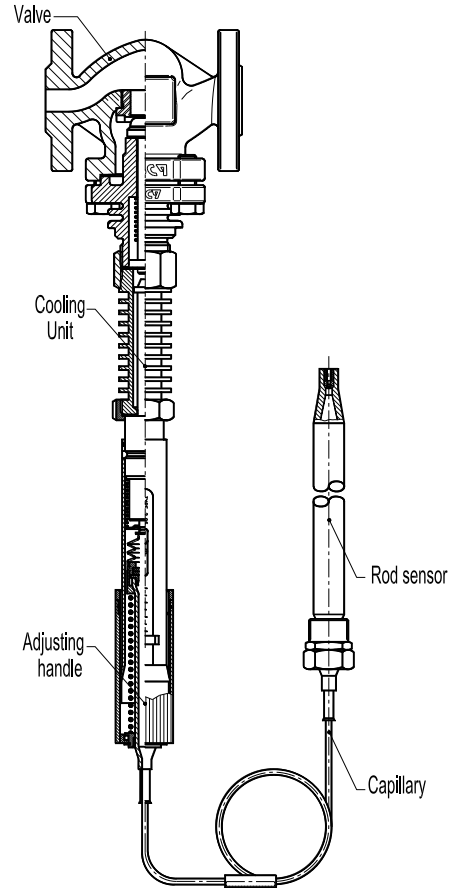

Sensor pocket PK

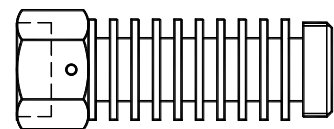

Cooling unit K1

BODY LIMITING CONDITIONS			
TR40S – PN40		TR40SS – PN40	
ALLOWABLE PRESSURE	RELATED TEMPERATURE	ALLOWABLE PRESSURE	RELATED TEMPERATURE
40 bar	-10 °C / 50 °C	40 bar	-10 °C / 50 °C
30,2 bar	200 °C	30,2 bar	200 °C
25,8 bar	300 °C	25,8 bar	300 °C
24 bar	350 °C	24 bar	350 °C
23,1 bar	400 °C	23,1 bar	400 °C

SPECIFICATIONS				
TYPE	Connect. DN	Opening Ø (mm)	Kvs (m³/h)	Valve stroke
TR40 – 15/4	15	4	0,2	6
TR40 – 15/6	15	6	0,45	6
TR40 – 15/9	15	9	0,95	6
TR40 – 15/12	15	12	1,7	6
TR40 – 15/15	15	15	2,75	6
TR40 – 20/9	20	9	0,95	6,5
TR40 – 20/15	20	15	2,75	6,5
TR40 – 20/20	20	20	5	6,5
TR40 – 25/20	25	20	5	7
TR40 – 25/25	25	25	7,5	7

MAX. PERMISSIBLE DIF. PRESSURES		
WITH T.205 THERMOSTAT		
PRESS. (bar)	VALVE SIZE (DN)	SEAT Ø (mm)
21	15	4 and 6
13	15	9
9,3	15	12
5,3	15	15
5,3	20	15
2,9	20	20
2,9	25	20
1,3	25	25

MAX. PERMISSIBLE DIF. PRESSURES		
WITH T.405 THERMOSTAT		
PRESSURE (bar)	VALVE SIZE (DN)	SEAT Ø (mm)
40	15	4 and 6
38	15	9
24	15	12
15	15	15
15	20	15
9	20	20
9	25	20
4,7	25	25

PROPORTIONAL BAND

The proportional band is the temperature change required for the valve to move from fully open to fully closed. It depends on the valve stroke and on the thermostat movement per °C, and is calculated as follows:

$$\text{Proportional band: } \frac{\text{Valve stroke (mm)}}{\text{Thermostat mov. (mm/°C)}}$$

Thermostat movement in mm per °C:

T.205 and T.405: 0,5 mm / °C

A proportional band in the range 8-13°C is suitable for most applications. A smaller proportional band is not ideal where heat loads vary rapidly.

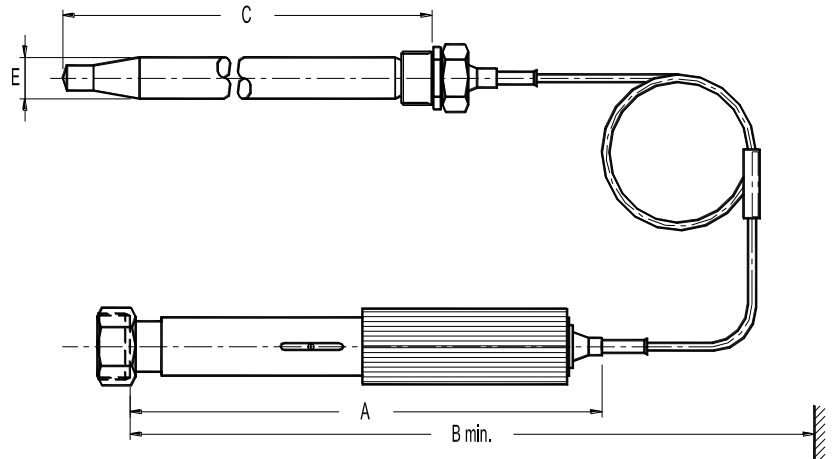

DIMENSIONS – THERMOSTAT (mm)					
TYPE	A	B	C	E	WGT. (kg)
T.205	305	405	210	22	1,8
T.405	385	525	390	22	2,6

DIMENSIONS – VALVE BODY (mm)

SIZE	A	B	C	WGT. (kg)
1/2"	130	48	115	4,8
3/4"	150	53	115	4,9
1"	160	58	120	5,9

MATERIALS

POS. Nº	DESIGNATION	MATERIAL	MATERIAL
1	Body	ASTM A216WCB/1.0619; GP240GH / 1.0619	CF8M / 1.4408
2	Bonnet	CK45 / 1.1191	CF8 / 1.4308
3	* Gasket	St. steel / Graphite	St. steel / Graphite
4	* Valve plug	AISI 316 / 1.4401	AISI 316 / 1.4401
5	Seat	AISI 316 / 1.4401	AISI 316 / 1.4401
6	* Spring	AISI 302 / 1.4300	AISI 302 / 1.4300
7	Guide	AISI 316 / 1.4401	AISI 316 / 1.4401
8	Washer	AISI 304 / 1.4301	AISI 304 / 1.4301
9	Bolts	Steel 8.8	A-2

* Available spare parts.

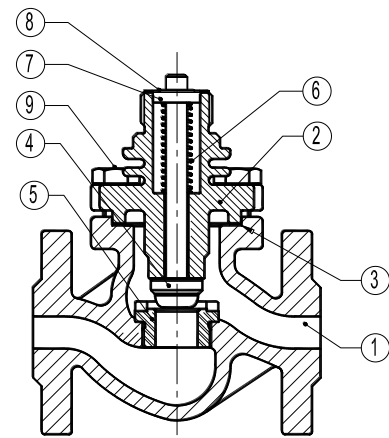
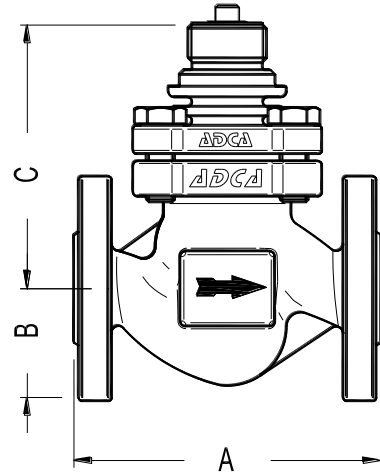

COOLING UNITS K1

The cooling units are used in connection with control valves and thermostats to protect the stuffing box. At valve temperatures between 150 °C and 250 °C a cooling unit of type K1 connected downwards should be applied. For higher temperatures as well as for all hot oil systems please consult.

SENSOR POCKETS PK

Sensor pockets made of stainless steel can be supplied to all TR series self-acting thermostats with rod sensors. They are used where it is impossible to empty the system or the tank.

The use of sensor pockets implies delay of heat transfer to the rod sensors and thus a longer reaction time for the controllers. This is, to some extent, counteracted by filling up the sensor pockets with paste or oil.

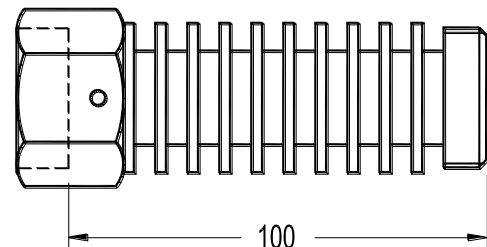

INSTALLATION

The installation site for the sensor pocket is arbitrary when paste is applied. When using oil, the sensor pocket must point at least slightly downwards.

MATERIAL

Stainless steel 1.4436.

LIMITING CONDITIONS

40 bar at 120 °C;
24 bar at 350 °C.

POCKET DIMENSIONS (mm)

TYPE	D	H	L	S	R
PK2	25	9	218	36	1"
PK4	25	10	390	45	1 1/4"

