

PRESSURE OPERATED PUMPS PPA14

DESCRIPTION

The ADCAMat PPA14 pressure operated pump is recommended in the transfer of steam condensate, oils and other non-hazardous liquids compatible with the construction, to a higher elevation or pressure. Under certain conditions, it can drain a closed vessel under vacuum or pressure. The pump can be operated using steam, compressed air or other gases, and is manufactured in carbon steel or stainless steel.

OPERATION

Liquid flows by gravity into the pump through an inlet check valve, lifting the float. At this point, the motive fluid intake valve is closed while the vent valve is open. As the float reaches its highest position the motive fluid intake valve opens and the vent valve closes, allowing the motive fluid to enter the pump body. The pressure in the pump builds up just enough to overcome backpressure.

The pressurized liquid opens the outlet check valve and the discharge starts. The liquid discharged may be quantified through a special counter, enabling the pump to function as a reliable flow meter.

When the float reaches its lower position the motive fluid intake valve closes and the vent valve opens allowing the liquid to fill the pump once again, repeating the cycle.

MAIN FEATURES

- Hardened stainless steel wear parts.
- High-endurance inconel spring.
- Low filling head to minimize installation space.
- No electric requirements or NPSH issues.
- Suitable for hazardous environments.
- Low running costs.

OPTIONS: Level gauge.
Stroke counters.

USE: To lift steam condensate and other liquids compatible with the construction.

AVAILABLE MODELS: PPA14S – carbon steel.
PPA14SS – stainless steel.

SIZES: 2" x 2" and 3" x 2";
DN 50 x DN 50 and DN 80 x DN 50.
Others on request.

CONNECTIONS: Flanged EN 1092-1 PN 16.
Flanged ASME B16.5 Class 150.
Female threaded ISO 7 Rp (threaded flanges).
Others on request.

INSTALLATION: Horizontal installation. An example is shown in Fig. 1.
See IMI – Installation and maintenance instructions.

MOTIVE MEDIUM: Saturated steam, compressed air, nitrogen and other gases.



CE MARKING – GROUP 2 (PED – EUROPEAN DIRECTIVE)

PN 16	CATEGORY
All sizes	3 (CE marked)

BODY LIMITING CONDITIONS *

PPA14S		PPA14SS		RELATED TEMP.
FLANGED PN 16 / CLASS 150	FLANGED PN 16	FLANGED CL. 150	FLANGED CL. 150	
ALLOW. PRESS.	RELATED TEMP.	ALLOW. PRESS.	ALLOW. PRESS.	
16 bar	50 °C	16 bar	15,3 bar	50 °C
14 bar	100 °C	15 bar	13,3 bar	100 °C
13 bar	195 °C	12,7 bar	11,1 bar	200 °C
12 bar	250 °C	12 bar	10,2 bar	250 °C

* Rating according to EN 1092-1:2018.

LIMITING CONDITIONS

Liquid specific gravity	0,8 to 1
Maximum viscosity	5° Engler
Maximum motive inlet pressure	10 bar
Minimum motive inlet pressure	1 bar
Maximum operating temperature	185 °C
Minimum operating temperature	0 °C
Pump discharge per cycle	25 L

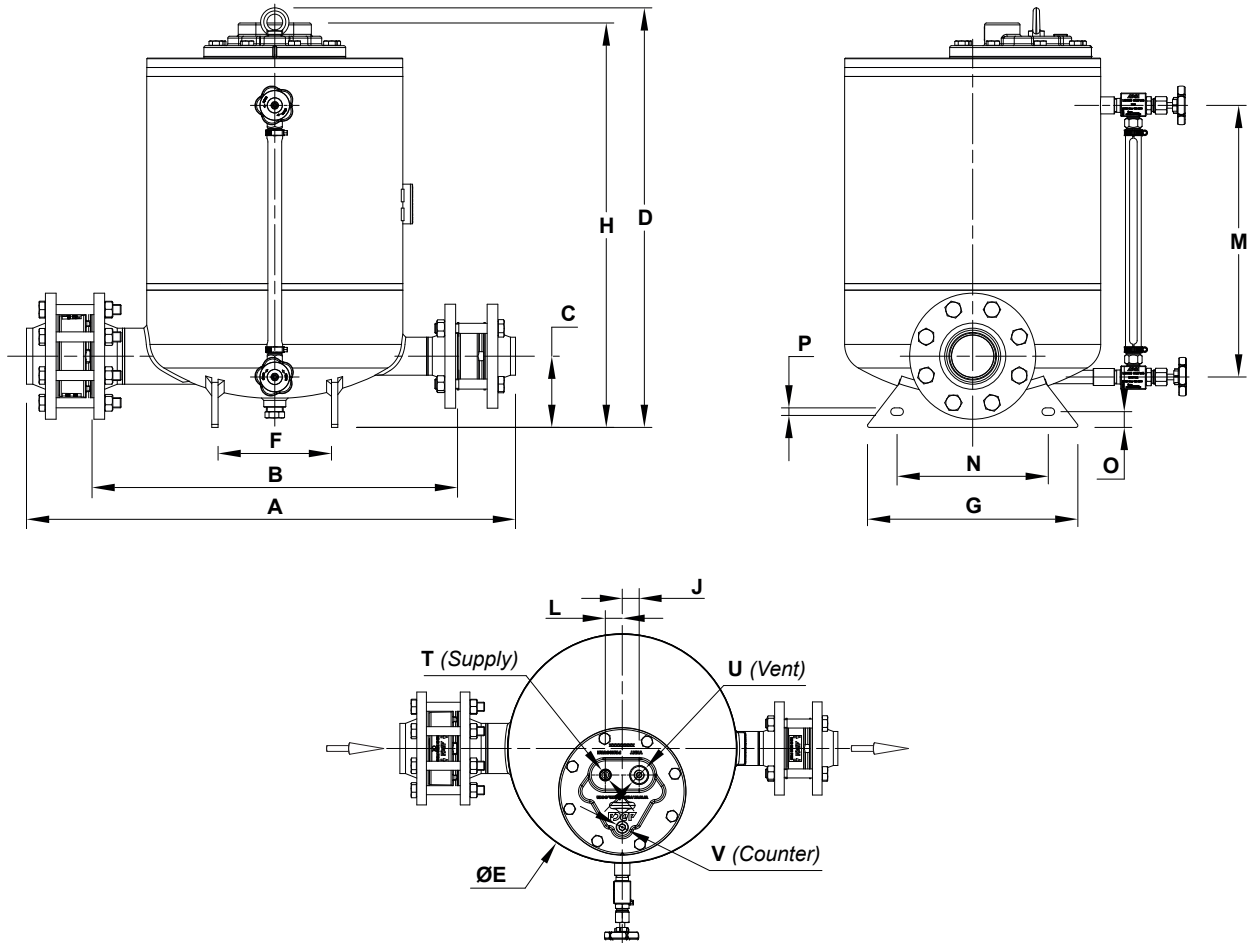

DIMENSIONS (mm)

SIZE	A *	B *	C	D	ØE	F	G	H	J	L	M	N	O	P	T **	U **	V **	VOL. (L)	WGT. (kg)
2" x 2" DN 50 x 50	764	580	113	666	406	180	334	642	30	30	431	240	25	12	1/2"	1"	1/2"	67,5	115
3" x 2" DN 80 x 50	775	580	113	666	406	180	334	642	30	30	431	240	25	12	1/2"	1"	1/2"	68	123

* With EN 1092-1 welding neck flanges. Dimensions may differ if ASME B16.5 flanges or ISO 7 Rp female threaded flanges are requested. Consult the manufacturer.

** As standard, in versions manufactured with EN 1092-1 PN 16 flanges, these connections are female threaded ISO 7 Rp. In versions with ASME B16.5 flanges, these connections are female threaded NPT.

MATERIALS

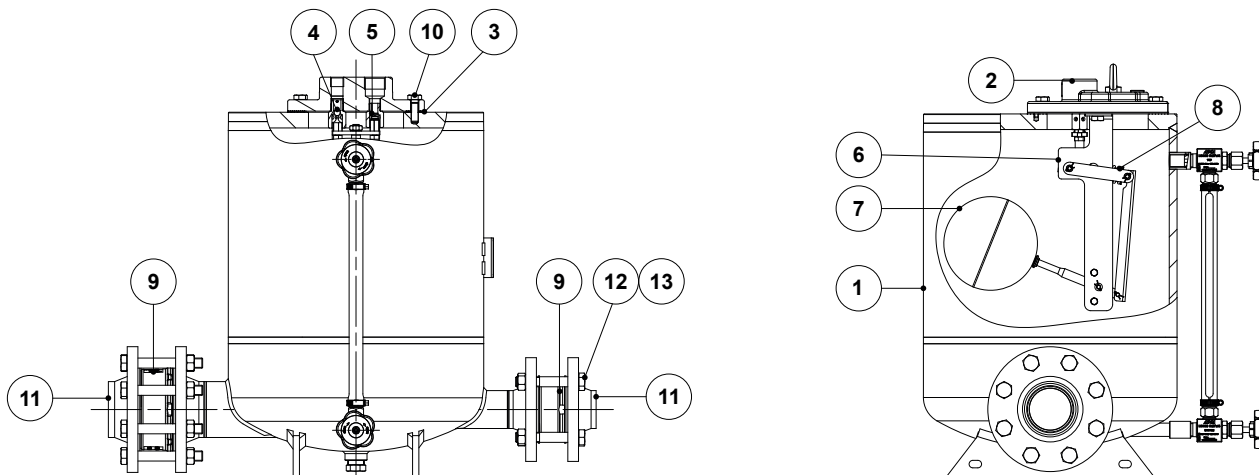

MATERIALS			
POS. No.	DESIGNATION	PPA14S	PPA14SS
1	Pump body	P265GH / 1.0425; P235GH / 1.0345; S235JR / 1.0038	AISI 316 / 1.4401; AISI 304 / 1.4301
2	Cover	GJS-400-15 / 0.7040 ; A216 WCB / 1.0619	AISI 316 / 1.4401
3	* Cover gasket	Stainless steel / Graphite	Stainless steel / Graphite
4	* Intake valve/seat assembly	Stainless steel	Stainless steel
5	* Exhaust valve/seat assembly	Stainless steel	Stainless steel
6	Lever assembly	Stainless steel	Stainless steel
7	* Float	Stainless steel	Stainless steel
8	* Spring assembly	Inconel	Inconel
9	* Check valve	A351 CF8M / 1.4408	A351 CF8M / 1.4408
10	Bolt	Steel 8.8	Stainless steel A2-70
11	Counter flange	P250GH / 1.0460	AISI 316 / 1.4401
12	Bolt	Zinc plated steel	Stainless steel A2-70
13	Nut	Zinc plated steel	Stainless steel A2-70

* Available spare parts.

SIZING

To accurately size a pressure operated pump, the following information must be provided:

1. The condensate load (kg/h).
2. The operating medium (steam, compressed air or other gases) and its pressure.
3. The total lift or backpressure in bar the pump will have to overcome. This includes the change in fluid level elevation after the pump (0.0981 bar/m of lift), plus pressure in the return piping, plus the pressure drop caused by pipe friction and other system components.
4. Available filling head in mm or any other dimension that allows its determination.

Table 1

CAPACITY CORRECTION FACTOR FOR GASES OTHER THAN STEAM					
% BACKPRESSURE VS MOTIVE PRESSURE (BP/MP)	10%	30%	50%	70%	90%
Correction factor	1,04	1,08	1,12	1,18	1,28

Table 2

CAPACITY CORRECTION FACTORS FOR FILLING HEADS OTHER THAN 300 mm				
PUMP SIZE	FILLING HEAD (mm)			
	150	300	600	900
2" x 2" – DN 50 x 50	0,7	1	1,2	1,35
3" x 2" – DN 80 x 50	0,9	1	1,08	1,2

RECEIVER

A receiver is recommended to temporarily hold the liquid and prevent any flooding of the equipment, while the pump is performing a pumping cycle. A definable length of large diameter pipe can be used. Suggested receiver sizes are shown in Table 3.

Table 3

RECEIVER		
PUMP SIZE	2" x 2" – DN 50 x 50	3" x 2" – DN 80 x 50
Pipe Ø x length (mm)	323 x 1000	

Table 4

FLOW RATE (kg/h) INSTALLATION WITH 300 mm FILLING HEAD ABOVE THE PUMP COVER			
MOTIVE PRESSURE (bar)	TOTAL LIFT (bar)	2" x 2" – DN 50 x 50	3" x 2" – DN 80 x 50
1	0,35	2240	3710
1,7		3290	5470
3,5		3530	5820
5		3580	5970
7		3625	6010
10		3810	6290
1,7	1	2670	3570
3,5		3120	5160
5		3220	5360
7		3330	5470
10		3515	5790
2,5	1,5	2085	3435
3,5		2890	4835
5		2980	4980
7		3040	5080
10		3315	5390
3,5	3	2160	2890
4		2540	3440
5		2840	3780
7		2980	4040
10		3230	4430
4,5	4	1910	2505
5		2060	2680
7		2240	2990
10		2530	3385

Remark: Based on liquid specific gravity of 0,9 to 1,0.

Example

Condensate load	3500 kg/h
Filling head	150 mm
Motive fluid	Compressed air
Available pressure	7 bar
Vertical lift after pump	10 m
Return piping pressure	1,2 bar
Piping friction pressure drop	Negligible

Calculations:

Total backpressure: $1,2 \text{ bar} + (10 \text{ m} \times 0,0981) = 2,181 \text{ bar}$.

Assuming steam as motive medium at a pressure of 7 bar and a total backpressure of 3 bar, then according to Table 4 a DN 80 x 50 pump, with a capacity of 4040 kg/h, is the recommended size.

Filling head correction:

With 150 mm filling head the correction factor from Table 2 is 0,9. The corrected capacity is thus $4040 \text{ kg/h} \times 0,9 = 3636 \text{ kg/h}$.

Correction for air as a motive medium:

The % backpressure is $2,181 \text{ bar} / 7 \text{ bar} = 31\%$. The correction factor from Table 2 is 1,08.

The corrected capacity is thus $3636 \text{ kg/h} \times 1,08 = 3926,88 \text{ kg/h}$, and so, a DN 80 x 50 pump is still the recommended size.

TYPICAL APPLICATIONS

CONDENSATE RECOVERY IN AN OPEN LOOP SYSTEM

The pump transfers high temperature condensate without cavitation problems. The vent line must be unrestricted and self draining to the receiver (Fig. 1).

REMOVAL OF CONDENSATE UNDER PRESSURE WITH PUMP AND STEAM TRAP COMBINATION

The pump is installed in a closed loop with its vent connected to a pressurized receiver (Fig. 2). When steam pressure is sufficient to overcome backpressure, the steam trap operates. As soon as, e.g., the equipment's control valve starts to modulate, the steam pressure will decrease (even vacuum can occur). The lower differential pressure decreases the steam trap ability to discharge, causing the condensate level to rise inside the body of the pump. Once the pump float reaches its higher position, the intake valve opens and steam replaces the necessary positive pressure to pump out the condensate.

DRAINAGE OF A SINGLE UNIT UNDER VACUUM

This configuration works with units operating with a minimum absolute pressure of 0,2 bar (Fig. 3). For proper operation the filling head (H1) must range between 1 and 2 meters. The lift (H) must be as minimum as possible, but never less than 1 meter, otherwise a siphon with height (H2) is required. Steam must be used as motive medium, and its maximum pressure should not exceed 3 bar.

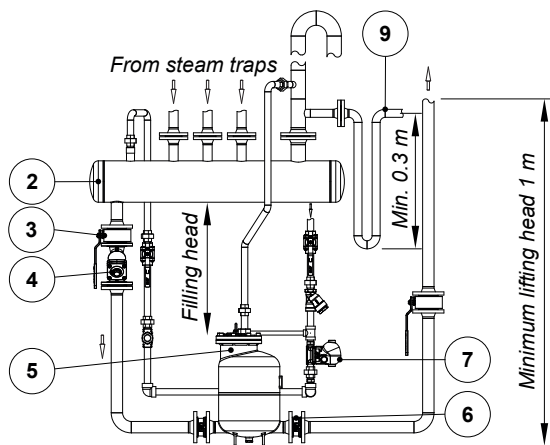

Fig. 1

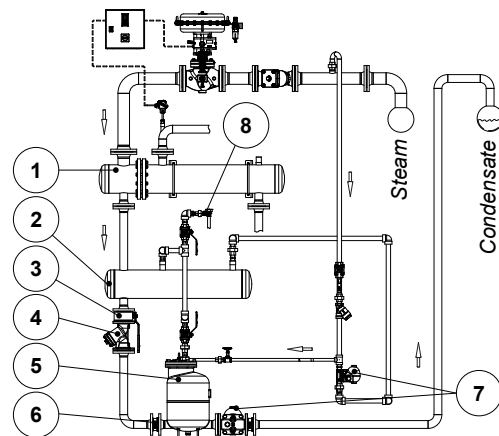

Fig. 2

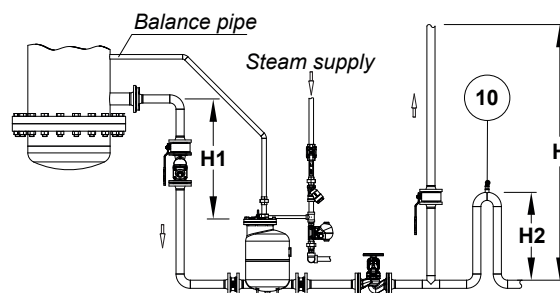

Fig. 3

EQUIPMENT			
POS. No.	DESIGNATION	POS. No.	DESIGNATION
1	Heat exchanger	6	Check valve
2	Receiver	7	Steam trap
3	Shut-off valve	8	Air vent
4	Y strainer	9	Overflow
5	Pump	10	Vacuum breaker