

AUTOMATIC PUMP TRAPS APST

DESCRIPTION

The ADCAMat APST automatic pump trap is specially recommended where stall condition may occur due to poor steam trap condensate discharge capacity, caused by temporary insufficient pressure drop.

The equipment combines the features of a float steam trap and a pressure operated pump, in one single unit.

Whenever the steam trap function is incapable of draining condensate, the pump function is activated (using external steam pressure). The pump replaces the necessary positive pressure to lift the condensate to the return system, before water logging occurs, avoiding water hammer and consequent noise, equipment damage, corrosion, unstable temperature control, etc.

MAIN FEATURES

- High capacity.
- Hardened stainless steel wear parts.
- High-endurance inconel springs.
- Low filling head to minimize installation space.
- No electric requirements or NPSH issues.
- Suitable for hazardous environments.
- Low running costs.
- No motive or flash steam is lost.
- Operation under vacuum conditions.

OPTIONS: Level gauge.

USE: Drain and lift steam condensate from heat exchangers, among others.

AVAILABLE MODELS:

- APSTS – carbon steel.
- APSTS-HC – carbon steel, high capacity.
- APSTSS – stainless steel.
- APSTSS-HC – stainless steel, high capacity.

SIZES: 2" x 2" and 3" x 2";
DN 50 x DN 50 and DN 80 x DN 50.

CONNECTIONS: Flanged EN 1092-1 PN 16.
Flanged ASME B16.5 Class 150.
Female threaded ISO 7 Rp (threaded flanges).
Others on request.

INSTALLATION: Horizontal installation in a closed loop system.
An example is shown in Fig. 1.
See IMI – Installation and maintenance instructions.

MOTIVE MEDIUM: Saturated steam.



CE MARKING – GROUP 2 (PED – EUROPEAN DIRECTIVE)	
PN 16	CATEGORY
All sizes	2 (CE marked)

LIMITING CONDITIONS	
Minimum density	0,80 kg/L
Maximum motive pressure	10 bar
Minimum motive pressure	1 bar
Maximum operating temperature	185 °C
Minimum operating temperature	0 °C
Pump discharge per cycle (approx.)	22 L

Remark: It is recommended that the motive pressure does not exceed 1 to 4 bar above the expected back pressure applied to the pump.

BODY LIMITING CONDITIONS *

APSTS		APSTSS		
FLANGED PN 16 / CLASS 150		FLANGED PN 16	FLANGED CLASS 150	RELATED TEMPERATURE
ALLOWABLE PRESSURE	RELATED TEMPERATURE	ALLOWABLE PRESSURE	ALLOWABLE PRESSURE	
16 bar	50 °C	16 bar	15,3 bar	50 °C
14 bar	100 °C	15 bar	13,3 bar	100 °C
13 bar	195 °C	12,7 bar	11,1 bar	200 °C
12 bar	250 °C	12 bar	10,2 bar	250 °C

* Rating according to EN 1092-1:2018.

FLOW RATE CAPACITY (kg/h) OPERATING IN STEAM TRAP MODE

MODEL	SIZE	DIFFERENTIAL PRESSURE (bar)									
		0,1	0,3	0,5	0,7	1	1,5	2	4,5	7	10
APST	2" x 2" – DN 50 x 50	1800	3000	3900	4450	5000	6100	7100	10000	13750	16000
APST-HC	2" x 2" – DN 50 x 50	2400	5900	7550	9050	11000	14000	15500	22500	26500	30000
APST	3" x 2" – DN 80 x 50	1800	3000	3900	4450	5000	6100	7100	10000	13750	16000
APST-HC	3" x 2" – DN 80 x 50	2400	5900	7550	9050	11000	14000	15500	22500	26500	30000

FLOW RATE CAPACITY (kg/h) OPERATING IN PUMP MODE W/ 300 mm FILLING HEAD

MOTIVE PRESS. (bar)	TOTAL LIFT (bar)	2" x 2" DN 50 x 50	3" x 2" DN 80 x 50
1	0,35	2290	2640
2		3130	3610
3		3530	4070
4		3810	4390
6		3910	4500
8		3960	4570
10		3970	4580
2	1	2520	2910
3		2960	3420
4		3130	3610
6		3220	3710
8		3250	3750
10	3290	3800	
3	2	2440	2810
4		2590	2990
5		2800	3220
6		2830	3270
8		2850	3290
10	2870	3300	
4	3	2330	2680
5		2510	2900
6		2530	2920
8		2560	2960
10	2620	3030	
5	4	2250	2600
6		2430	2810
8		2470	2860
10	2510	3010	
6	5	2050	2370
8		2150	2490
10		2190	2540
7	6	1850	2140
8		1910	2210
10		2120	2450

RECEIVER SIZING TABLE FOR EQUALIZED, CLOSED SYSTEM INSTALLATION

FLOW RATE (kg/h)	RECEIVER SIZE (DN)						
	40	50	80	100	150	200	250
	RECEIVER LENGTH (mm)						
≤ 300	1200	700	–	–	–	–	–
400	1500	1000	–	–	–	–	–
500	2000	1200	500	–	–	–	–
600	–	1500	600	–	–	–	–
800	–	2000	800	500	–	–	–
1000	–	–	1000	700	–	–	–
1500	–	–	1500	1000	–	–	–
2000	–	–	2000	1300	600	–	–
3000	–	–	–	2000	900	500	–
4000	–	–	–	–	1200	700	–
5000	–	–	–	–	1400	800	500
6000	–	–	–	–	1700	1000	600
7000	–	–	–	–	2000	1200	700
8000	–	–	–	–	–	1300	800
9000	–	–	–	–	–	1500	900
10000	–	–	–	–	–	1700	1000

Remark: Receiver length can be reduced by 50% when the motive inlet pressure divided by the backpressure is ≥ 2 .

CAPACITY CORRECTION FACTORS FOR FILLING HEADS OTHER THAN 300 mm

PUMP SIZE	FILLING HEAD "H" (mm)			
	150	300	600	900
All sizes	0,7	1	1,2	1,35

Remark: Filling head "H" is shown in Fig. 1.

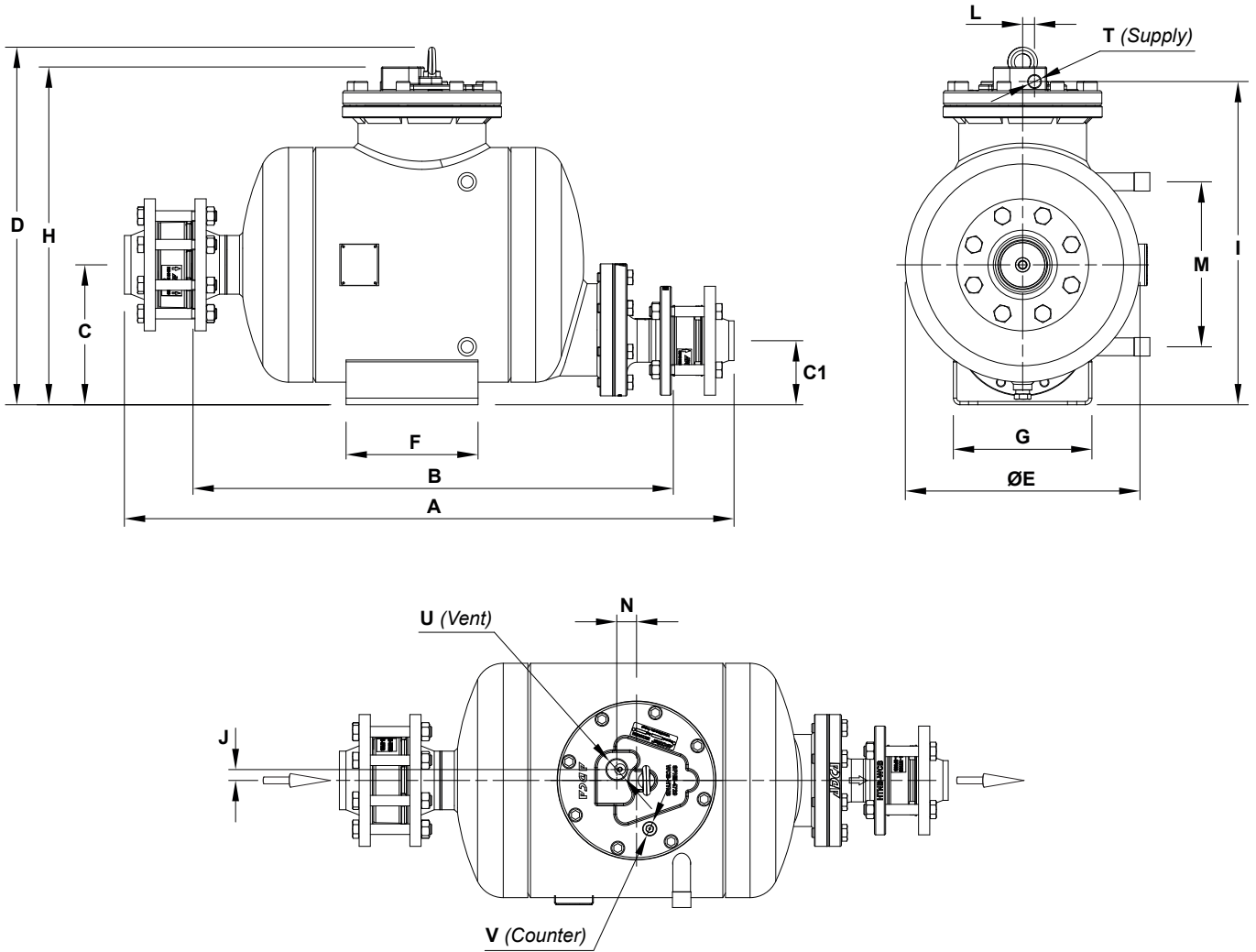

DIMENSIONS – PN 16 (mm)

SIZE	A *	B *	C	C1	D	ØE	F	G	H	I	J	L	M	N	T **	U **	V **	VOL. (L)	WGT. (kg)
DN 50 x 50	910	726	212	97	542	356	200	210	512	490	17	18	250	30	1/2"	1"	1/2"	45	84
DN 80 x 50	924	728	212	97	542	356	200	210	512	490	17	18	250	30	1/2"	1"	1/2"	45	91

DIMENSIONS – CLASS 150 (mm)

SIZE	A *	B *	C	C1	D	ØE	F	G	H	I	J	L	M	N	T **	U **	V **	VOL. (L)	WGT. (kg)
2" x 2"	958	743	212	97	542	356	200	210	512	490	16	18	250	30	1/2"	1"	1/2"	45	86
3" x 2"	980	748	212	97	542	356	200	210	512	490	16	18	250	30	1/2"	1"	1/2"	45	90

* Dimensions are different if ISO 7 Rp female threaded flanges are requested.

** As standard, in versions manufactured with EN 1092-1 PN 16 flanges, these connections are female threaded ISO 7 Rp. In versions with ASME B16.5 flanges, these connections are female threaded NPT.

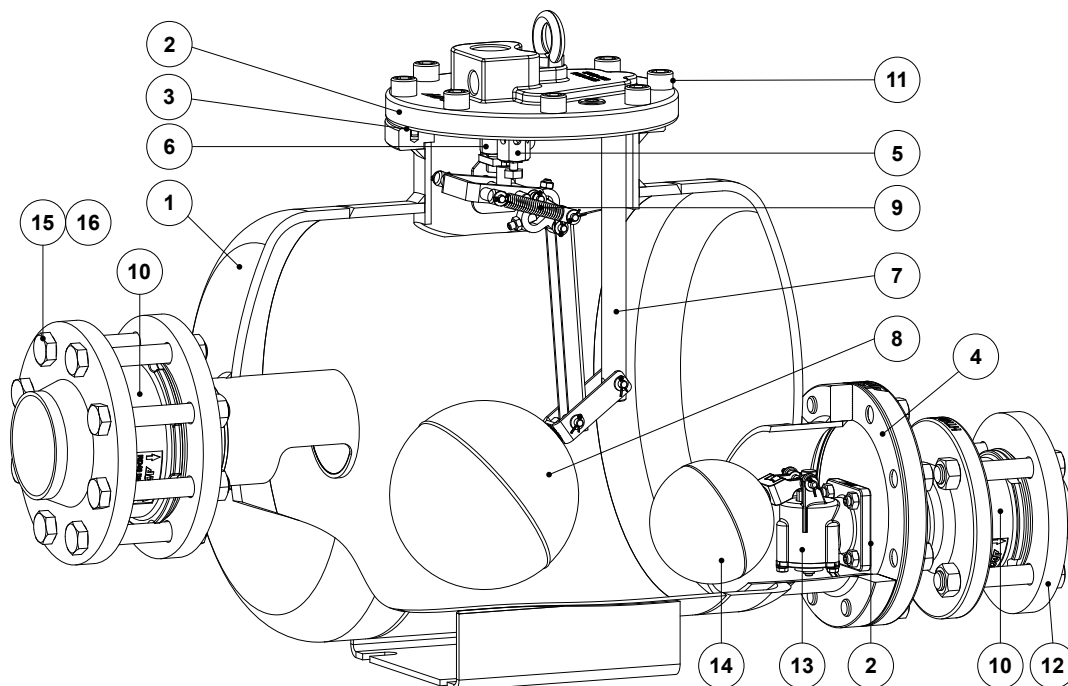

MATERIALS

POS. No.	DESIGNATION	APSTS	APSTSS
1	Body	P265GH / 1.0425 ; P235GH / 1.0345; S235JR / 1.0038; P250GH / 1.0460	AISI 316 / 1.4401; AISI 316L / 1.4404
2	Cover	WCB / 1.0619	A351 CF8M / 1.4408
3	* Cover gasket	Stainless steel / Graphite	Stainless steel / Graphite
4	* Outlet cover gasket	Stainless steel / Graphite	Stainless steel / Graphite
5	* Intake valve/seat assembly	Stainless steel	Stainless steel
6	* Exhaust valve/seat assembly	Stainless steel	Stainless steel
7	Lever assembly	Stainless steel	Stainless steel
8	* Float	Stainless steel	Stainless steel
9	Spring assembly	Inconel	Inconel
10	* Check valve	A351 CF8M / 1.4408	A351 CF8M / 1.4408
11	Bolt	Steel 8.8	Stainless steel A2-70
12	Counter flange	P250GH / 1.0460	AISI 316 / 1.4401
13	* Steam trap mechanism	Stainless steel	Stainless steel
14	* Steam trap float	Stainless steel	Stainless steel
15	Bolt	Zinc plated steel	Stainless steel A2-70
16	Nut	Zinc plated steel	Stainless steel A2-70

* Available spare parts.

SIZING

To accurately size a pump trap, the following information must be provided:

1. Heat exchanger (or process equipment) maximum steam or condensate load, in kg/h.
2. Heat exchanger (or process equipment) operating pressure at full load in bar or, alternatively, the heat exchanger maximum operating pressure in bar and the over design percentage.
3. Motive steam pressure available to operate the pump trap, in bar.
4. The total lift or backpressure in bar the pump will have to overcome. This includes the change in fluid level elevation after the pump (0.0981 bar/m of lift), plus pressure in the return piping, plus the pressure drop caused by pipe friction and other system components.
5. Maximum controlled temperature of the medium to be heated (secondary fluid outlet temperature), in °C.
6. Minimum temperature of the medium to be heated (secondary fluid minimum inlet temperature), in °C.
7. Available filling head (H) in mm or any other dimension that allows its determination. See Fig. 1.

For information on how to predict stall refer to IS 9.085 Technical Information Sheet - Understanding stall condition - or consult the manufacturer.

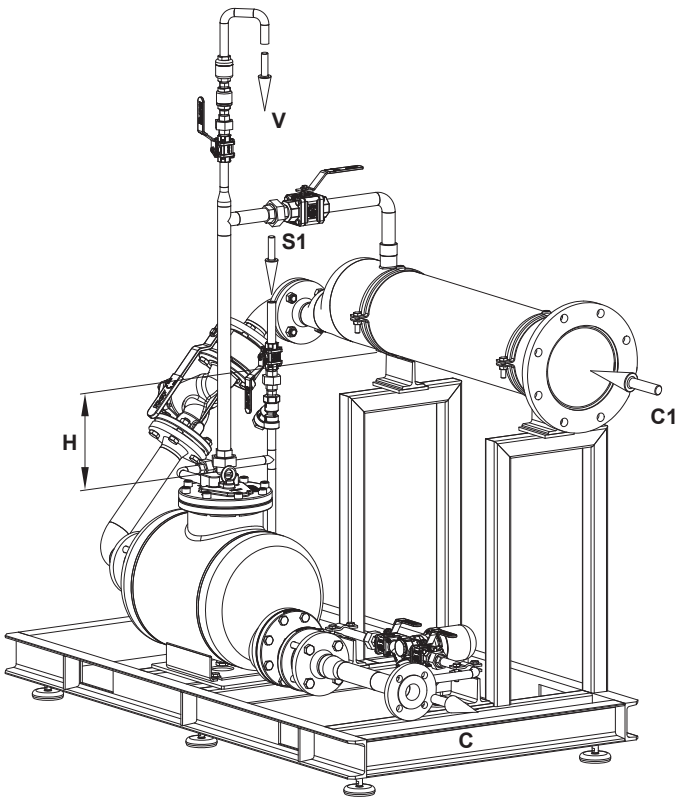

Fig. 1

- H* – Filling head
S1 – Motive steam
C1 – Condensate from heat process
C – Condensate return
V – Automatic air venting

RECEIVER

A receiver is recommended to temporarily hold the liquid and prevent any flooding of the equipment, while the pump is performing a pumping cycle. A definable length of large diameter pipe can be used. See receiver sizing table.

NOTE: All ADCAMat automatic pump traps feature two mechanisms, combining the characteristics of a float steam trap and a pressure operated pump.

When certain that the system backpressure is always superior to the equipment upstream pressure then an ADCAMat pressure operated pump (without steam trap) is the ideal solution as long as it is installed in a closed loop.

In extreme cases, where the system condensate load is above the discharge capacity of all ADCAMat automatic pump trap models, it is recommended to install an ADCAMat pressure operated pump in combination with a high capacity FLT series steam trap. In such scenarios, please consult the manufacturer.

OPERATION

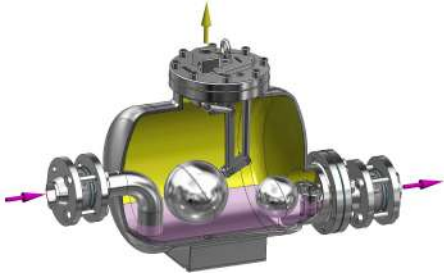

1. In the first instance, the steam intake valve is closed, while the vent valve is open. As condensate flows into the body through the inlet check valve, the APST can operate in a closed loop application, in one of two ways (as a steam trap or pressure operated pump).

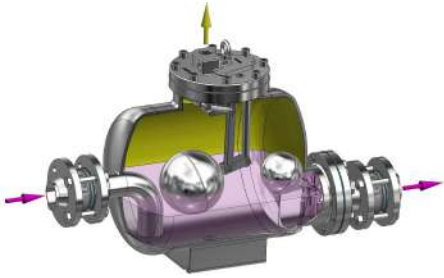

2. If the inlet pressure is greater than the back pressure, the APST works as a steam trap, continuously discharging condensate by differential pressure. At this point, the steam intake valve remains closed and the vent valve open.

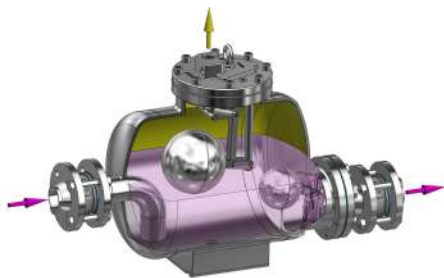

3. As soon as, e.g., the equipment control valve starts to modulate, the steam pressure will decrease. The lower differential pressure decreases the APST's ability to discharge as a steam trap, causing the condensate level to rise inside the body. Vacuum may even occur at this stage.



4. If this situation would persist, the condensate would eventually flood the equipment, causing problems. However, by using an APST, as the float reaches its highest position, the snap action mechanism actuates, closing the vent valve and opening the steam intake valve. Steam will then replace the necessary positive pressure to pump out the condensate. At this point, the APST works as a pressure operated pump.

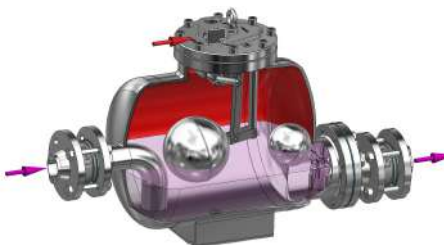

5. The float starts to fall as the condensate level inside the body drops and is discharged to the return system. When the float reaches its lowest position, the snap action mechanism resets.

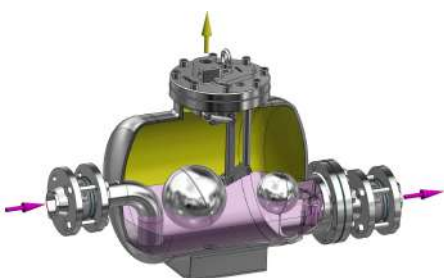

6. As the motive steam valve closes and the vent valve opens, equalizing the body pressure with the upstream pressure, the condensate is allowed to flow once again into the APST. The cycle then repeats itself and, with enough differential pressure, the APST resumes as a steam trap or, otherwise, as a pump.