

COMPRESSED AIR BALL FLOAT TRAPS FA21SS (Stainless Steel)

DESCRIPTION

FA21SS series compressed air float traps are specially designed for draining water from high pressure compressed air and gas lines.

Applications on aftercoolers, separators and compressed air and gas mains.

An air balance pipe must be fitted allowing the air trapped in the trap body to escape, avoiding obstructing of condensate flow.

Connections are flanged or female screwed.

MAIN FEATURES

Modulating discharge.

Unaffected by sudden or wide load and pressure changes.



OPTIONS: Equalizing and drain plug on body.
Lifting lever.

USE: Compressed air and non corrosive gas compatible with the construction.

AVAILABLE MODELS: FA 21SS-21.

SIZES: DN 1/2" - 1", DN 15 - DN 25.

CONNECTIONS: Female screwed ISO 7/1Rp(BS21)
Flanged EN 1092-1 PN40 or ANSI.

INSTALLATION Horizontal or vertical installation.

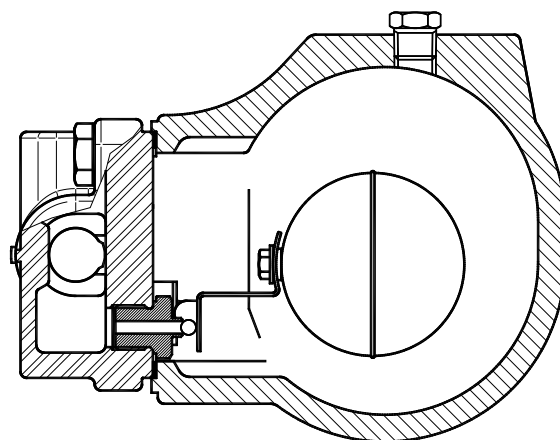

BODY LIMITING CONDITIONS		
FLANGED PN25 / ANSI 300*	FLANGED ANSI 150 **	RELATED TEMP.
ALLOW. PRES.	ALLOW. PRES.	
25 bar	16 bar	100 °C
22,7 bar	14,8 bar	150 °C
21 bar	13,6 bar	200 °C
19,8 bar	12 bar	250 °C

PMO - Max. operating pressure 21 bar

TMO - Max. operating temperature 200 °C

* According to EN1092-1:2007 ; ** Acc. to EN1759-1:2004

Body limiting conditions PN25 or below, depending on the type of connection adopted. Rating PN25 for thread, SW and BW.

APPLICATION LIMITS	
Min. Liquid specific weight	0,75 Kg/dm ³
Maximum working dif. pressure-FA21-21	21 bar

FLOW RATE CAPACITY IN Kgs/h																
MODEL	SIZE	DIFFERENTIAL PRESSURE (bar)														
		0,5	1	1,5	2	3	4,5	6	7	8	9	10	12	14	16	21
FA21SS	15 - 25	75	100	125	155	180	220	255	275	290	305	320	345	375	420	480

DIMENSIONS (mm)											
Screwed						EN PN16/40		ANSI 150		ANSI 300	
SIZE DN	A	B	C	D	WGT. Kgs	F	WGT. Kgs	F	WGT. Kgs	F	WGT. Kgs
15-1/2"	95	178	23	128	5,2	150	6,7	150	6,2	150	7
20-3/4"	95	178	23	128	5,2	150	7,4	150	6,6	150	8,2
25-1"	95	178	23	128	5,2	160	7,8	160	7,4	160	9

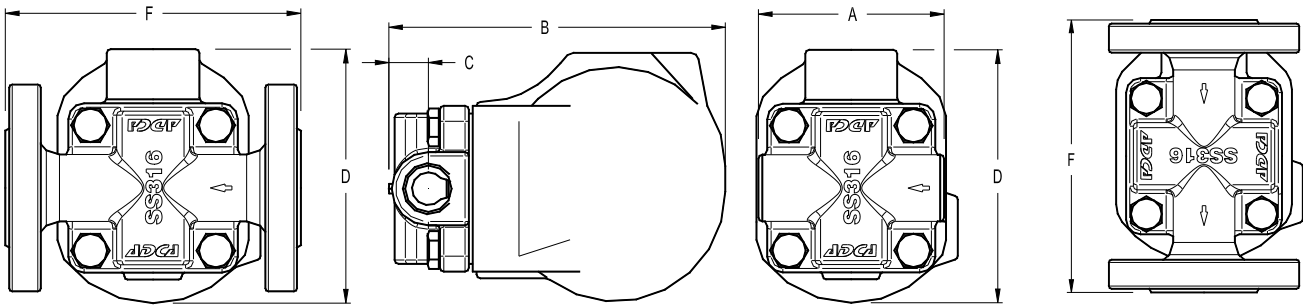
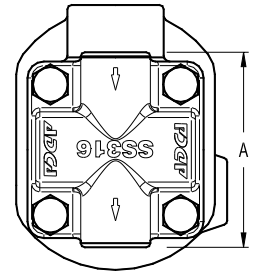

MATERIALS		
POS.Nr.	DESIGNATION	MATERIAL
1	Body	CF8M / 1.4408
2	Cover	CF8M / 1.4408
3	*Gasket	Stainless st./Graphite
4	*Seat	AISI 410 / 1.4006
5	*Valve	VITON ** AISI 410 / 1.4006
6	*Lever	AISI 304 / 1.4301
7	*Float	AISI 304 / 1.4301
8	**Compression fitting	St. Steel or Steel Fe / Zn
9	Bolts	St. Steel A2-70

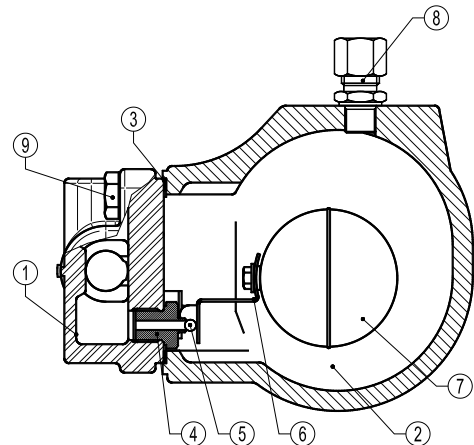

*Available spare parts. **Optional

Typical Installation

