

FLOAT AND THERMOSTATIC STEAM TRAPS FLT14I (Stainless steel 1"HC – DN 25HC)

DESCRIPTION

FLT14I float and thermostatic (integral air vent) steam traps series are designed for all types of low and high pressure steam heating and process equipment.

Typical applications include unit heaters, heat exchangers, driers, jacketed vessels and all the applications where continuous drainage is essential.

Connections are female screwed or flanged for horizontal or vertical installation.

MAIN FEATURES

Modulating discharge.

Discharges condensate at steam temperature.

Unaffected by sudden or wide load and pressure changes.

Excellent air discharge (by thermostatic air vent).

- OPTIONS:** SLR – steam lock release.
Equalizing plug or vent connection.
- USE:** Saturated and superheated steam.
- AVAILABLE MODELS:** FLT14I-4,5, 10 and 14.
- SIZES:** 1"HC – DN 25HC.
- CONNECTIONS:** Female screwed ISO7/1 Rp (BS21).
Flanged EN 1092-1 PN16 or ANSI.
- INSTALLATION:** Standard horizontal installation –
From left to right FLT14I (L-R).

Upon request:

- horizontal installation with the flow from right to left (R-L).
- vertical installation with the flow from top to bottom (V).

MAX. DIFFERENTIAL PRESSURE

- FLT14I-4,5 : 4,5 bar
FLT14I-10 : 10 bar
FLT14I-14: 14 bar



BODY LIMITING CONDITIONS		
FLANGED PN16 *	FLANGED ANSI 150 lb **	RELATED TEMPERATURE
ALLOW. PRESS.	ALLOW. PRESS.	
16 bar	16 bar	100 °C
14,5 bar	14,8 bar	150 °C
13,4 bar	13,6 bar	200 °C
12,7 bar	12 bar	250 °C

PMO – Max. operating pressure 14 bar

TMO – Max. operating temperature 198 °C

*Acc. to EN1092-2:2018 ; **Acc. to EN1759-1:2004
Body limiting conditions PN16 or below, depending on the type of connection adopted. PN16 for thread.

CE MARKING – GROUP 2 (PED – European Directive)	
PN16	Category
DN 25HC	SEP

FLOW RATE CAPACITY (kg/h)														
MODEL	SIZE	DIFFERENTIAL PRESSURE (bar)												
		0,5	1	1,5	2	3	4,5	6	7	8	9	10	12	14
FLT14I-4,5	1"HC – 25HC	900	1250	1450	1700	2010	2400	–	–	–	–	–	–	–
FLT14I-10	1"HC – 25HC	450	620	790	880	1100	1250	1500	1600	1700	1750	1800	–	–
FLT14I-14	1"HC – 25HC	340	435	530	600	610	850	990	1100	1190	1240	1300	1350	1380

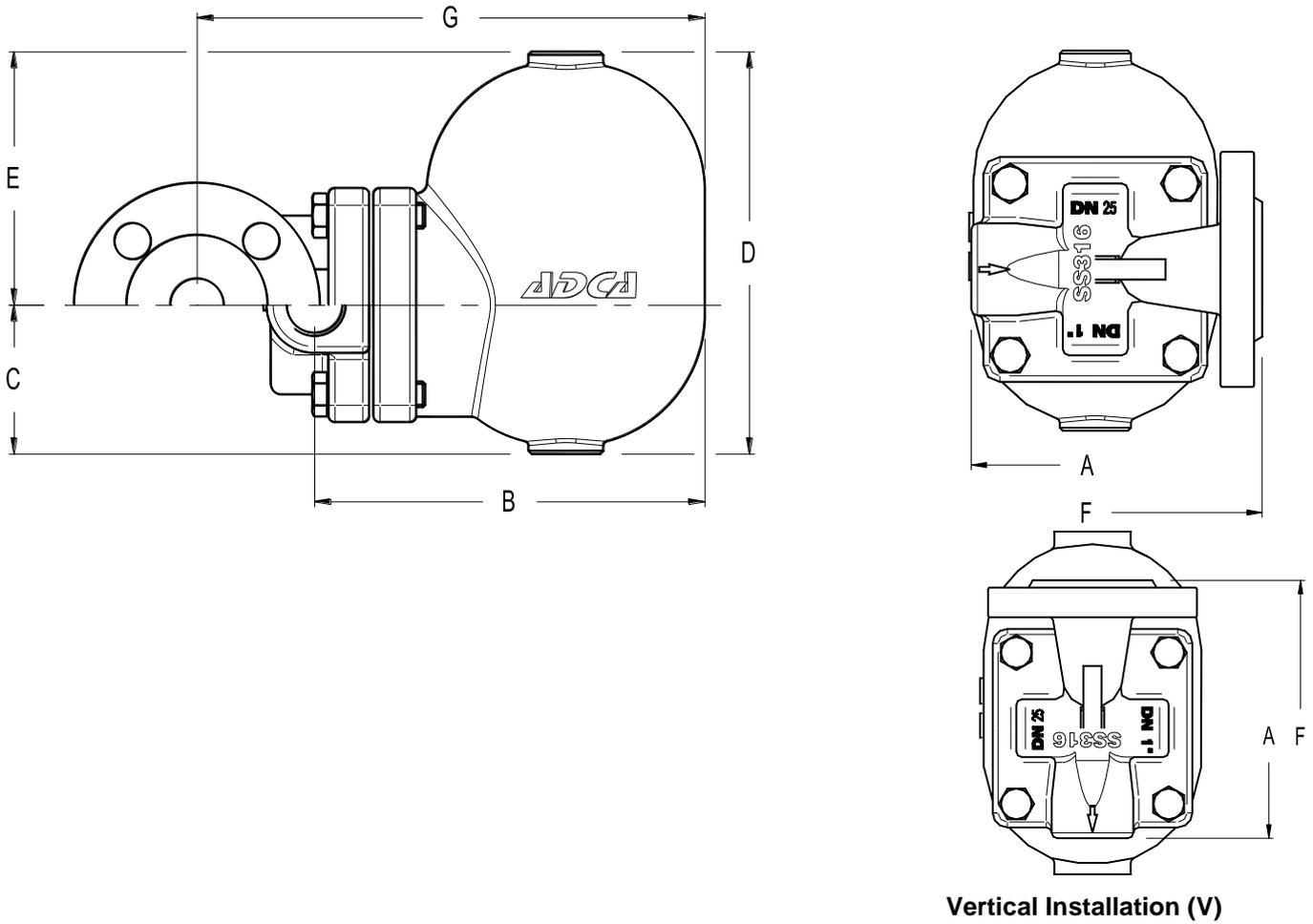

DIMENSIONS (mm)												
SIZE	Screwed						EN PN16			ANSI 150 lb		
	A	B	C	D	E	WGT. (kg)	F	G	WGT. (kg)	F	G	WGT. (kg)
1"HC - 25HC	120	195	80	190	110	9	160	248	11,3	160	248	10,9

MATERIALS		
POS. N°	DESIGNATION	MATERIAL
1	Body	CF8M / 1.4408
2	Cover	CF8M / 1.4408
3	*Gasket	Stainless steel / Graphite
4	*Seat	AISI 410 / 1.4006
5	*Valve	AISI 440C / 1.4125
6	*Lever	AISI 304 / 1.4301
7	*Float	AISI 304 / 1.4301
8	*Air vent	Stainless st. (bimetallic)
9	Bolts	Stainless steel A2-70

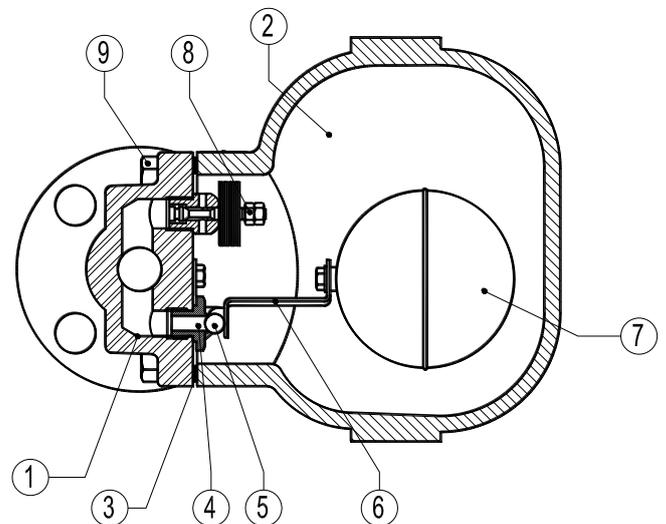

* Available spare parts.