

## FLOAT AND THERMOSTATIC STEAM TRAPS FLT32 (Cast steel 1"HC – DN 25HC)

### DESCRIPTION

FLT32 float and thermostatic (integral air vent) steam traps series are designed for all types of low and high pressure steam heating and process equipment.

Typical applications include unit heaters, heat exchangers, driers, jacketed vessels and all the applications where continuous drainage is essential.

Connections are female screwed or flanged for horizontal or vertical installation.

### MAIN FEATURES

Modulating discharge.

Discharges condensate at steam temperature.

Unaffected by sudden or wide load and pressure changes.

Excellent air discharge (by thermostatic air vent).

**OPTIONS:** SLR – steam lock release.  
Equalizing plug or vent connection.  
Internal strainer.

**USE:** Saturated and superheated steam.

### AVAILABLE MODELS:

FLT32-4,5 , 10 , 14 and 21

**SIZES:** 1"HC – DN 25HC

**CONNECTIONS:** Female screwed ISO7/1 Rp (BS21).  
Flanged EN 1092-1 PN40 or ANSI.

**INSTALLATION:** Standard horizontal installation –  
From left to right FLT32HC (L-R).

Upon request:

-horizontal installation with the flow from right to left (R-L).

-vertical installation with the flow from top to bottom (V).

### MAX. DIFFERENTIAL PRESSURE

FLT32HC-4,5 : 4,5 bar

FLT32HC-10 : 10 bar

FLT32HC-14: 14 bar

FLT32HC-21: 21 bar

CE MARKING (PED – European Directive)	
PN40	Category
DN 25 – 1"	1 (CE marked)



### BODY LIMITING CONDITIONS

FLANGED PN40 / ANSI 300 lb **	FLANGED ANSI 150 lb **	RELATED TEMPERATURE
ALLOW. PRESS.	ALLOW. PRESS.	
37,1 bar	15,4 bar	100 °C
33,3 bar	13,8 bar	200 °C
30,4 bar	12,1 bar	250 °C
27,6 bar	10,2 bar	300 °C

PMO – Max. operating pressure 32 bar

TMO – Max. operating temperature 250 °C

\*Acc. to EN1092-1:2007 ; \*\*Acc. to EN1759-1:2004

Body limiting conditions PN40 or below, depending on the type of connection adopted. Rating PN40 for thread, SW and BW.

### FLOW RATE CAPACITY (kg/h)

MODEL	SIZE DN	DIFFERENTIAL PRESSURE (bar)														
		0,5	1	1,5	2	3	4,5	6	7	8	9	10	12	14	16	21
FLT32-4,5	25HC	900	1250	1450	1700	2010	2400									
FLT32-10	25HC	450	620	790	880	1100	1250	1500	1600	1700	1750	1800				
FLT32-14	25HC	340	435	530	600	610	850	990	1100	1190	1240	1300	1350	1380		
FLT32-21	25HC	230	330	400	440	535	630	720	800	840	900	920	1020	1120	1260	1270

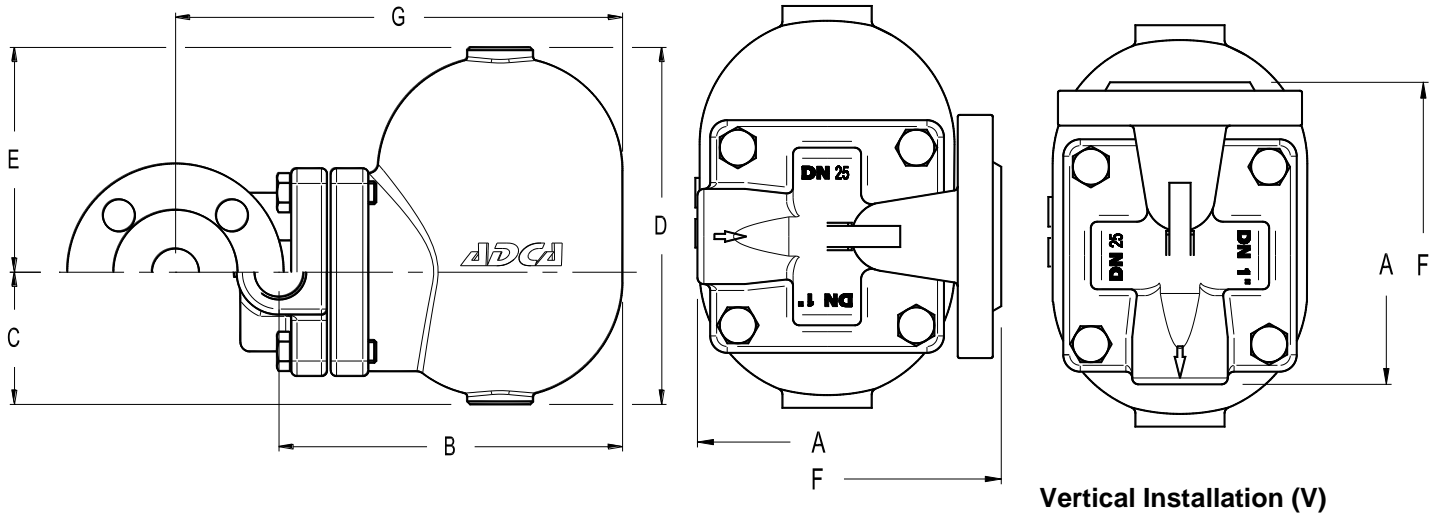

DIMENSIONS (mm)																								
Screwed							EN PN16 / 40			EN PN16 / 40*			ANSI 150 lb			ANSI 150 lb *			ANSI 300 lb			ANSI 300 lb *		
SIZE	A	B	C	D	E	WT. (kg)	F	G	WT. (kg)	F	B	WT. (kg)	F	G	WT. (kg)	F	B	WT. (kg)	F	G	WT. (kg)	F	B	WT. (kg)
1" - 25	120	195	80	190	110	9	160	248	11,3	230	195	12	160	248	11	230	195	11,2	160	248	11,3	230	195	12,8

\* Alternative.

MATERIALS		
POS. N°	DESIGNATION	MATERIAL
1	Body	GP240GH / 1.0619
2	Cover	GP240GH / 1.0619
3	*Gasket	Stainless steel / Graphite
4	*Seat	AISI 410 / 1.4006
5	*Valve	AISI 440C / 1.4125
6	*Lever	AISI 304 / 1.4301
7	*Float	AISI 304 / 1.4301
8	*Air vent	Stainless st. (bimetallic)
9	Bolts	Steel 8.8
10	**Strainer	AISI 304 / 1.4301

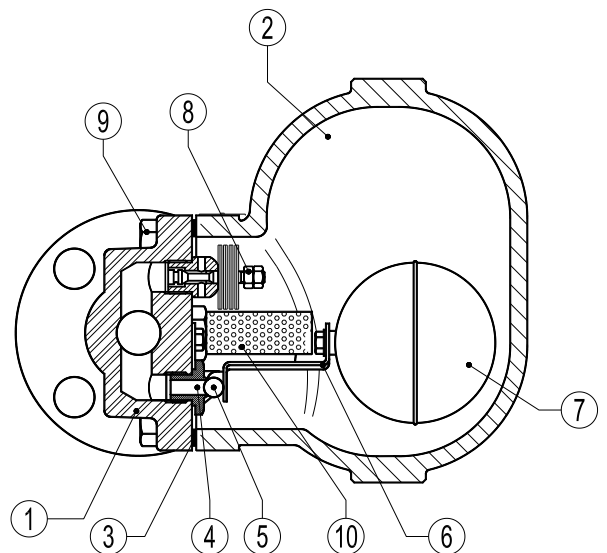

\* Available spare parts.; \*\* Optional.